

POSITIONS	CONTACTS	A		B	
		INCH	MM	INCH	MM
		±.015	±0.38	±.012	±0.30
3	3	.100	2.54	.165	4.19
4	4	.150	3.81	.215	5.46
5	5	.200	5.08	.265	6.73
6	6	.250	6.35	.315	8.00
7	7	.300	7.62	.365	9.27
8	8	.350	8.89	.415	10.54
9	9	.400	10.16	.465	11.81
10	10	.450	11.43	.515	13.08
11	11	.500	12.70	.565	14.35
12	12	.550	13.97	.615	15.62
13	13	.600	15.24	.665	16.89
14	14	.650	16.51	.715	18.16
15	15	.700	17.78	.765	19.43
16	16	.750	19.05	.815	20.70
17	17	.800	20.32	.865	21.97
18	18	.850	21.59	.915	23.24
19	19	.900	22.86	.965	24.51
20	20	.950	24.13	1.015	25.78
21	21	1.000	25.40	1.065	27.05
22	22	1.050	26.67	1.115	28.32
23	23	1.100	27.94	1.165	29.59
24	24	1.150	29.21	1.215	30.86
25	25	1.200	30.48	1.265	32.13
26	26	1.250	31.75	1.315	33.40
27	27	1.300	33.02	1.365	34.67
28	28	1.350	34.29	1.415	35.94
29	29	1.400	35.56	1.465	37.21
30	30	1.450	36.83	1.515	38.48
31	31	1.500	38.10	1.565	39.75
32	32	1.550	39.37	1.615	41.02
33	33	1.600	40.64	1.665	42.29
34	34	1.650	41.91	1.715	43.56
35	35	1.700	43.18	1.765	44.83
36	36	1.750	44.45	1.815	46.10
37	37	1.800	45.72	1.865	47.37
38	38	1.850	46.99	1.915	48.64
39	39	1.900	48.26	1.965	49.91
40	40	1.950	49.53	2.015	51.18
41	41	2.000	50.80	2.065	52.45
42	42	2.050	52.07	2.115	53.72
43	43	2.100	53.34	2.165	54.99
44	44	2.150	54.61	2.215	56.26
45	45	2.200	55.88	2.265	57.53
46	46	2.250	57.15	2.315	58.80
47	47	2.300	58.42	2.365	60.07
48	48	2.350	59.69	2.415	61.34
49	49	2.400	60.96	2.465	62.61
50	50	2.450	62.23	2.515	63.88

\*Indicated Temperature and time is for component Insulator. Higher processing temperatures may be used, provided heat is applied from back side of PCB, and Insulator does not exceed indicated temperature and time.

REVISIONS				
REV.	ECO. NO	DESCRIPTION	DATE	BY
A	1439	INITIAL RELEASE	07/25/07	RAH
B	1660	ADD TOLERANCE TO TABLE	04/15/08	ASK

PART NUMBER CODING

LPPB\_ \_1NGCN-RC

NUMBER OF POSITIONS  
(03 - 50)

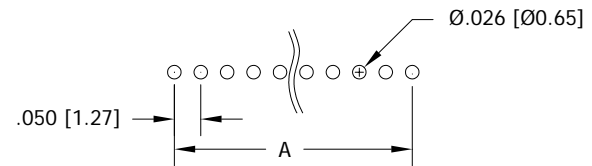
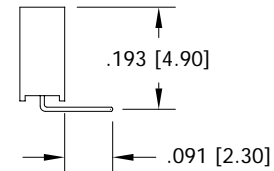
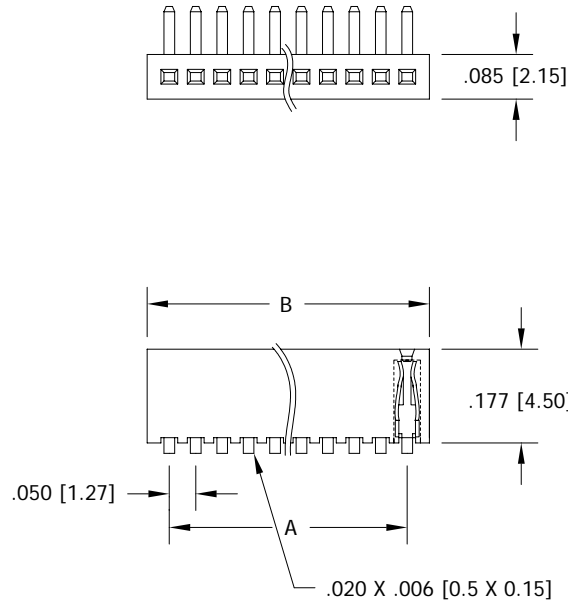

RECOMMENDED P.C. BOARD HOLE LAYOUT

NOTES:

- INSULATOR MATERIAL: L.C.P.  
\*PROCESSING TEMPERATURE = 260° C FOR 10 SEC
- CONTACT MATERIAL: PHOSPHOR BRONZE
- PLATING: GOLD FLASH OVERALL
- OPERATING TEMPERATURE: -40°C TO +105°C
- INSULATION RESISTANCE: 5000 MEGA OHM MIN.
- CONTACT RESISTANCE: 20 MILLI OHM MAX.
- UL FLAMMABILITY RATING: 94V-0
- VOLTAGE RATING: 500 VAC MINIMUM AT SEA LEVEL.
- CURRENT RATING: 1 AMP



RoHS COMPLIANT

UNLESS OTHERWISE SPECIFIED: DIMENSIONS ARE IN INCHES[MM] TOLERANCES:		DRAWN	DATE	NAME
X. = ± .015 [0.38] .X = ± .011 [0.30] .XX = ± .010 [0.25] .XXX = ± .006 [0.15] .XXXX = ± .0005 [0.127]		07/20/07		RAH
PARENTHEICAL INFORMATION IS FOR REFERENCE ONLY INTERPRET GD&T PER: ANSI Y14.5-1984		THE INFORMATION HEREIN CONTAINS PROPRIETARY INFORMATION OF SULLINS ELECTRONICS AND IS NOT TO BE REPRODUCED, USED OR DISCLOSED TO OTHERS FOR ANY PURPOSES EXCEPT AS SPECIFICALLY AUTHORIZED IN WRITING BY AN OFFICER OF SULLINS ELECTRONICS.		
SULLINS ELECTRONICS		DESCRIPTION .050" SINGLE ROW FEMALE HEADER, 90°		
PART NUMBER LPPB_ _1NGCN-RC		SIZE DWG. NO. C 10961		
SCALE: NONE		REV B		
SHEET 1 OF 1		PRINT: 11/6/2007		